

## Unit 3: Microcomputers and Microprocessors

### Introduction

This unit focuses on popular microcomputer systems and microprocessors. Lesson 1 of this unit presents the architecture and I/O communications of microcomputer systems. Microprocessor, the brain of a microcomputer with its functional units, is described in Lesson 2. This lesson also includes description of arithmetic logic unit and control unit in detail. Lesson 3 provides the information of popular microprocessors, namely, CISC, RISC and special purpose of processors.

### Lesson 1: Microcomputer and Organization

#### 1.1 Learning Objectives

On completion of this lesson you will be able to:

- understand structure of a microcomputer
- understand communication techniques between processor and other devices
- understand telecommunications for distant microcomputer.

#### 1.2 Architecture of a Microcomputer

The most modern microcomputers utilize a motherboard, a single large circuit board containing the microprocessor unit (MPU), ROM, RAM, and other associated circuits. These elements are linked through a series of parallel metal lines etched into the motherboard called the system bus. The system bus carries three types of information; these are: control, address, and data. Control information is carried by a number of control lines, addresses by a number of address lines and data by data lines.

The width of the bus is important to the performance of the computer. The wider the bus, the more information can be carried at one time and the greater the throughput of the system. Most 16-bit microcomputers use 8 or 16-bit buses, 32-bit microcomputers use 8-bit, 16-bit, and 32-bit buses, while 64-bit microcomputers use 16-bit, 32-bit and 64-bit buses.

A number of slots provide access to the system bus (Figure 3.1). Input/output devices can be connected to the microcomputer through the slots and appropriate interface circuit boards. The slots can also be used to expand the RAM capability of the microcomputer.

## I/O Interface

*Serial and parallel interface.*

Communications between an input/output device and the MPU take place through an interface. The interface converts the data from a form used by one of these devices to a form acceptable by the other. It must also adjust for speed differences between the processor and the other device. The interface circuits of microcomputers correspond to the I/O control units used on larger computer systems.

Two general types of interface devices in use are serial and parallel. A serial interface transmits data as a string of bits, one bit after the other, over a single wire. A parallel interface transmits data byte by byte through a multiwire cable.

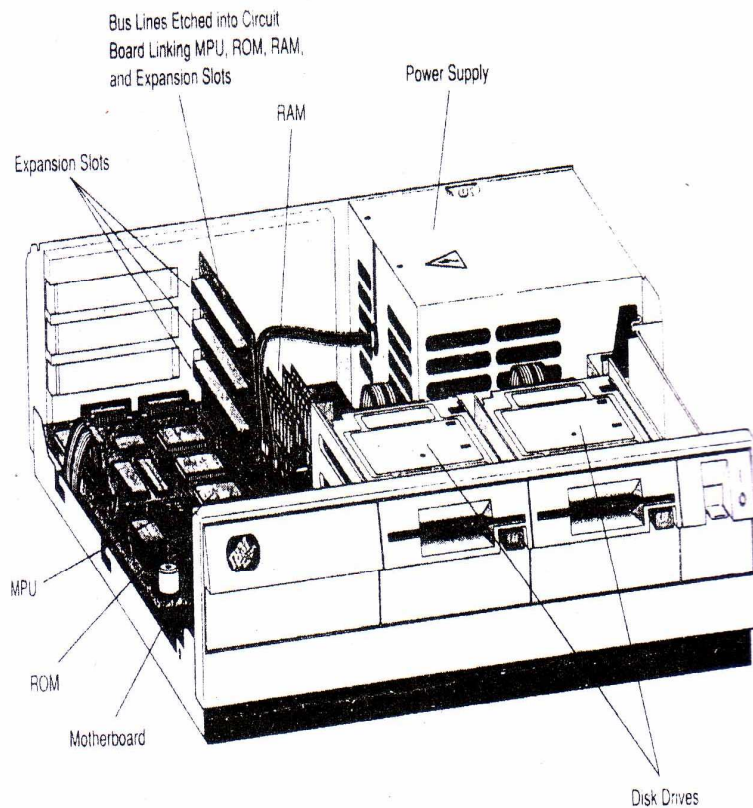

Figure 3.1 : Microcomputer architecture.

Parallel interface devices are faster, but are more costly. The interface must match the requirements of the device it supports.

System bus

Figure 3.2 illustrates some of the I/O devices generally connected to a microcomputer. These devices are linked through a common system bus. Communications between these devices take place over this bus, under control of the processor. Thus, the bus while carrying data from a disk device to memory, for example, cannot carry data to or from the keyboard, monitor, or any other I/O device.

Some microcomputer systems use a separate microprocessor to handle I/O operations. This frees the MPU to perform non-I/O operations on other programs while the separate processor handles the I/O operations for the current program.

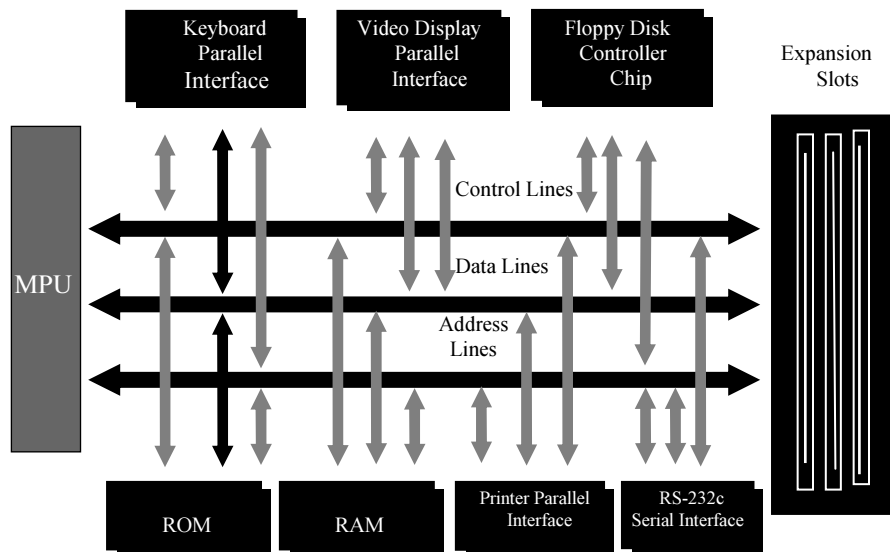

Figure 3.2 : Peripheral devices in a microcomputer.

### Input/Output Methods

There are three basic methods by which data can be read (or input) from or written (or output) to a peripheral device and RAM. These methods are referred to as: programmed I/O, interrupt I/O, and direct memory access.

In programmed I/O, the MPU directly controls all data transfers and other I/O operations. This is accomplished with input or output instructions. When an input operation is desired, the MPU issues an

input command and awaits the arrival of the data at the bus. From the bus the data are moved to memory. Similarly for an output operation, the MPU transmits the data to the bus and issues a command to the output device through the appropriate interface. Once data transfer is initiated, the MPU should wait for its completion and the bus to be freed before beginning a new transfer. This method is commonly used in personal computers.

*Interrupt I/O method*

In the interrupt I/O method, the MPU does not wait for the input/output devices to complete their tasks. The control of the operation is given to a channel. The channel signals the MPU when the operation has been completed. This is accomplished by means of an interrupt. Upon completion of the execution of the current instruction, the MPU may then initiate another I/O operation.

*Direct memory address method*

Direct memory address method is the fastest of the three methods. It requires a multibus architecture and allows the MPU to be bypassed completely. A direct memory access controller is connected between RAM and an input or output device. This method is the most expensive of the all and therefore is not used except with very high-speed input/output devices.

*Modem performs the functions of modulation and demodulation.*

### **Telecommunications Between Microcomputers**

Most microcomputers also support the transfer of data through telephone line. This is facilitated by means of an add-on device known as a modem. In telecommunications, one computer or terminal issues a command, or some form of output. This digital output from the computer, is modulated, or converted to an analog signal, by a modem interfaced to the sending computer. The signal is then carried over the telephone line and received at another modem some distance away. This second modem then demodulates, or converts the analog signal back to a computer-compatible digital signal. The name modem performs the functions of modulation and demodulation. Thus, with the aid of a modem and a serial interface to a microcomputer, communication can take place over long distances. The speed with which these communications take place is dependent on the modem employed.

### 1.3 Exercise

#### 1. Multiple choice questions

- a. Which of the following is the main component of the microcomputer?
  - (i) ROM
  - (ii) Microprocessor
  - (iii) Motherboard
  - (iv) Bus system.
  
- b. The fastest method by which data can be input from or output to a peripheral device and RAM are:
  - (i) Programmed I/O
  - (ii) Interrupt I/O
  - (iii) Direct memory access
  - (iv) Serial Input/Output.
  
- c. Which are the functions of modem?
  - (i) Analog to digital conversion
  - (ii) Modulation and demodulation
  - (iii) Digital to analog conversion
  - (iv) None of them.

#### 2. Questions for short answers

- a. What is a bus?
- b. What is the difference between serial and parallel interfaces?
- c. Write down the names of three of basic methods by which data can be input from or output to a peripheral device and RAM.

#### 3. Analytical question

- a. Describe the architecture and I/O interface of a microcomputer.

## Lesson 2: Basics of Microprocessors

### 2.1 Learning Objectives

On completion of this lesson you will be able to :

- describe functional units of a microprocessor
- understand working principles of arithmetic logic unit and control unit
- describe instruction cycle and instruction execution.

### 2.2 Microprocessor and its Functional Units

The microprocessor is an electronic device. It is the heart and brain inside every microcomputer. This tiny chip of silicon determines the speed and power of the entire computer by handling most, if not all, of the processing jobs in the machine. The microprocessor is composed of an arithmetic/logic unit and a control unit. Both utilize temporary storage areas, called registers, to perform their functions. These registers are: accumulator, instruction register, address register, and other special- and general-purpose registers. Primary storage is available on separate integrated circuits but is logically and electronically connected to the microprocessor. A system of wires linking these internal components and capable of transmitting electrical impulses is referred to as a bus. Most microcomputers use one or more internal or local buses for communicating within the microprocessor and a common or system bus for communicating with components outside the microprocessor.

*Microprocessor is the heart and brain inside every microcomputer.*

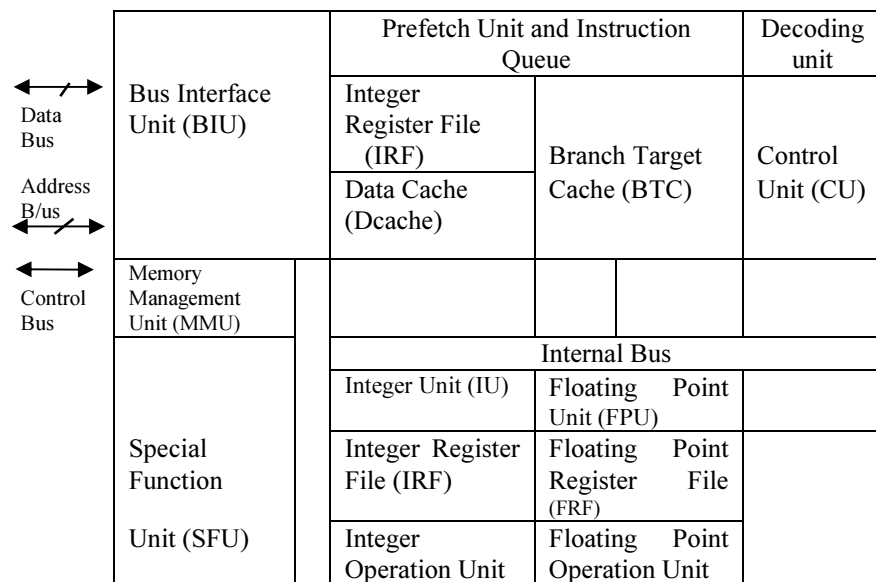

Figure 3.3 Block representation of a microprocessor.

### 2.3 Arithmetic/Logic Unit

*ALU performs all arithmetic operations, in addition to decision making functions.*

The arithmetic/logic unit (ALU) is the computer's calculator (Figure 3.4). It performs all arithmetic operations, in addition to decision making functions. A few current processors use multiple ALUs to attain high processing speeds. However, most microprocessors have a single ALU.

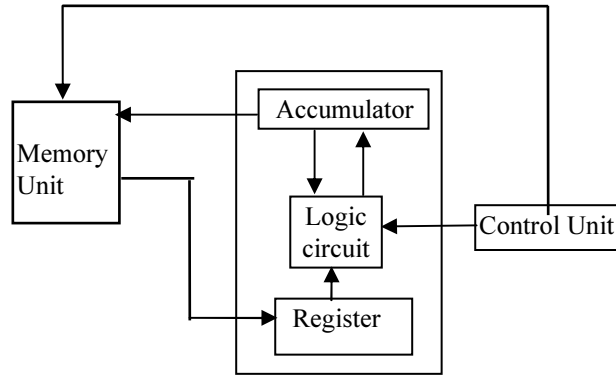

Fig. 3.4: Functional block diagram of an ALU.

Arithmetic operations include addition, subtraction, multiplication, and division. The data operated on can be stored in various forms: the binary, BCD, EBCDIC and ASCII representations.

The ALU makes use of temporary storage areas referred to as registers. Data to be arithmetically manipulated are copied from memory and placed in registers for processing. Upon completion of the arithmetic operation, the result can be transferred from the register to memory, freeing the register for the next arithmetic operation. In addition to registers, the ALU uses one or more adders, devices that actually add, subtract, multiply, or divide the binary digits.

### Decision Making

Decision making is the ability to compare two numbers to determine, if the first number is smaller than, equal to, or greater than the second number and to respond by taking an appropriate action based on the result of the comparison. For example, if the question is  $x > 100$ ; the ALU would determine answer as being either true or false depending on the memory contents. It is also possible to test for the existence of a condition during the processing of an application and to alter the sequence of instructions accordingly.

## 2.4 Control Unit

*Coordinates and controls operations of the central processing unit.*

The control unit performs the computer's traffic control. It coordinates and controls operations of the central processing unit. It does this like the human brain coordinates and controls the activities of the human body. The control unit does not input, output, process, or store data; rather, it initiates and controls these operations. The control unit also communicates with input devices to begin the transfer of data or instructions into storage and with output devices in order to begin the transfer of results from storage. Data transfer involves the moving of data or instructions from one location to another. When an item of data is stored in a given location, it replaces the previous contents of that location. But when an item of data is moved from one location to another the data item is not physically removed from its initial location; the data item is copied to the new location. When the computer executes a program contained in primary memory, the control unit obtains the instructions in the sequence in which they are executed, interprets these instructions, and issues signals to execute them. To accomplish this, the control unit must communicate with both the ALU and primary storage.

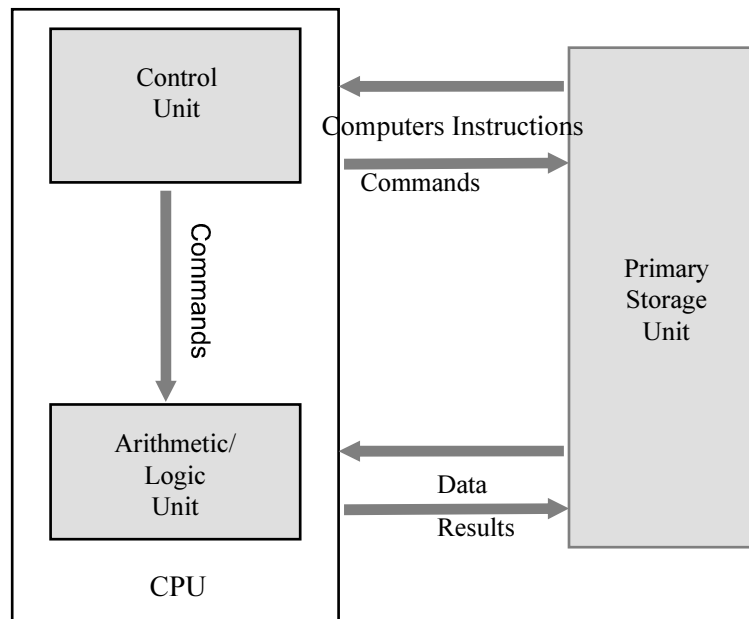

Figure 3.5 : Communication of Control Unit with ALU and Primary Storage Unit.



The control unit generally performs all or most of the following functions for execution of instructions :

- determines the instruction to be executed
- determines the operation to be performed
- determines what data are needed and where they are stored
- determines where results, if any, are to be stored
- determines where the next instruction is located
- causes the instruction to be executed
- transfers control to the next instruction.

### Machine Cycles

*Operations within the CPU of the computer take place in terms of a fixed number of clock pulses.*

The activities of the control unit, are composed of thousands of individual steps, each of which takes place in a fixed interval of time. These intervals are controlled by an internal electronic clock that emits ten million regular electronic pulses every second. Clock speeds are generally measured in megahertz (MHz) or million pulses per second. In general, operations within the central processing unit (CPU) of the computer take place in terms of a fixed number of clock pulses. This number determines the machine cycle for the computer. During a machine cycle, the computer can perform one machine operation. The number of machine operations required to execute a single instruction vary from instruction to instruction.

To illustrate this process, assume that the computer executes a move instruction (moving data from one place in the computer to another) and that this move instruction requires three separate machine operations for its completion. If a machine cycle is made up of five clock pulses, then the move instruction takes place in fifteen ticks of the clock. Thus, the total time required to complete the move is fifteen times the time interval of a single clock pulse. Execution of instructions takes place under the direct supervision of the control unit.

### Instruction Format

*Instruction format*

Program instructions stored in memory must be in a machine - readable form. In general, these instructions consist of two distinct parts-an operation code and one (or more) operand. The operation code, (Opcode) tells the machine what task is to be performed; the operands specify what are to be used to perform the task.

Examples of operands are :

- The address of a data item or an instruction in primary memory.
- The address of a data item or a program outside the CPU on a secondary memory.
- The address of an input or an output unit.
- The address of a register or special-purpose temporary memory area.

For example, the instruction

MOV 8000 9000

contains the operation code MOV and the operands 8000 and 9000. This could mean that the machine is to move the contents of storage location 8000 to storage location 9000. In addition to the address of an item of data in primary storage, an operand can be used to indicate the address of a register, the address of data stored in secondary storage, or even the address of an input or output device.

### **Instruction Execution**

#### *Instruction Execution*

The actual execution of an instruction such as the move instruction, generally requires a number of machine cycles. The instruction is retrieved from storage, interpreted, and executed. These functions generally require at least two machine cycles called instruction cycle and execution cycle.

### **Instruction Cycle**

The instruction cycle is the first machine cycle in the execution of an instruction. Four distinct steps are performed during the instruction cycle (Figure 3.6). These are:

#### *Instruction Cycle*

1. The instruction is fetched from primary storage and placed in a register called a storage register. This is accomplished by the control unit. When program execution is initiated, the instruction counter is set to the address of the first program instruction. As instructions are executed the instruction counter is updated so that it always contains the address of the next instruction to be executed.

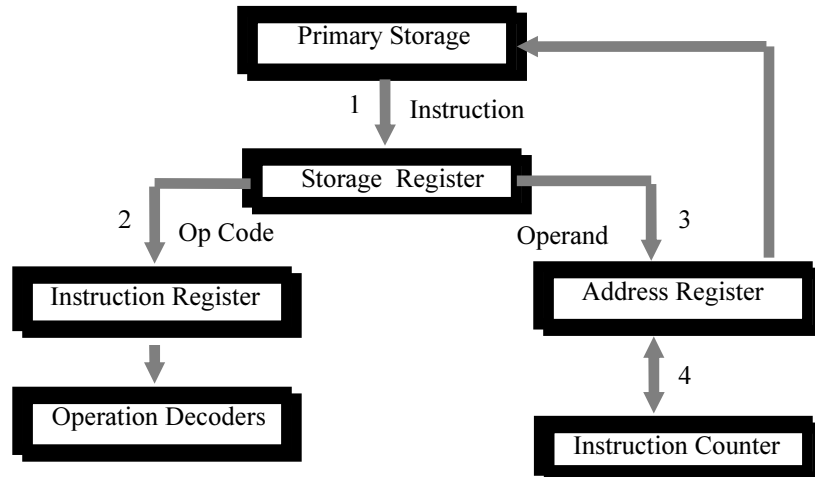

Figure 3.6: The instruction cycle.

2. The operation code is moved to the instruction register and decoded. This is accomplished with the aid of operation decoders.
3. The operands are placed in one or more address registers, depending on the number of operands in the instruction.
4. The address of the next instruction is determined.

Instructions are executed one after the other. Normally next instruction will be located immediately after the current instruction in storage. Its address is simply the address of the current instruction plus the number of locations occupied by the current instruction. Some times it becomes necessary in a program to branch, or transfer control, to an instruction other than the next instruction. In such cases, the current instruction indicates the address of the next instruction. This address is then placed in the instruction counter, and the sequential execution of instructions is resumed until another branch instruction is encountered.

### Execution Cycle

The execution cycle represents the remaining machine cycles in the execution of an instruction. Unlike the instruction cycle, the execution cycle may consist of more than one machine cycle. The time required to complete the execution cycle is referred to as execution time. Throughout this cycle, operations are controlled by the instruction register.

*Execution Cycle*

## Computer Basics

The steps performed in an execution cycle depend on the instruction being executed. Let us assume that a program requires that two numbers be added. During the instruction cycle the control unit would decode the instruction and direct the ALU to perform the ADD operation. It would also have placed the addresses of the operands in the address register. The execution cycle would cause the following :

1. The operands would be obtained from the primary locations indicated in the address register. One value would be placed in a storage register and the other would be placed in the accumulator register.
2. The ALU would then add these numbers.
3. The sum would be stored in the accumulator register.

The instruction cycle of the next instruction would begin. This instruction would most likely involve moving the content of the accumulator register (the sum of the two numbers) to a location in primary storage.

## 2.5 Exercise

### 1. Multiple choice questions

- a. Which one are the functional units of a microprocessor?
- (i) ALU and memory
  - (ii) control unit and register
  - (iii) ALU and control unit
  - (iv) control unit and storage.
- b. Which one is the function of the control unit?
- (i) to control computer traffic
  - (ii) to store information
  - (iii) to perform arithmetic operation
  - (iv) none of the above.

### 2. Questions for short answers

- a. What is a microprocessor?
- b. What are the functional units of a microprocessor?
- c. Briefly write the functions of ALU.
- d. Define the terms: register and operand.

### 3. Analytical questions

- a. Write an essay on functional units of a microprocessor.
- b. Describe the functions of the control unit.
- c. Describe the distinct steps performed during the instruction cycle.

## Lesson 3: Popular Microprocessors

### 3.1 Learning Objectives

On completion of this lesson you will be able to :

- develop the concept of different classes of microprocessors
- understand CISC and RISC processors
- know few examples of popular microprocessors.

### 3.2 Classification of Microprocessors

In general microprocessors can be classified as follows:

*CISC, RISC and Special purpose processors*

- (i) CISC - complex instruction set computers
- (ii) RISC - reduced instruction set computers, and
- (iii) special purpose processors.

The high performance demands of various applications have motivated the rapid development of microprocessor technology. This is based on (i) processing speed, (ii) processing ability, (iii) communication ability, and (iv) control ability. Every year new devices, new functions and new possibilities are introduced. An imaginative and effective architecture for today could be easily available for tomorrow. The classification made in this section is based on current microprocessors. These are briefly described below.

### 3.3 CISC

*CISC microprocessors are microcode operated.*

This class of microprocessors are microcode operated. Microcode is a set of instructions (software) for microprocessor that run invisibly inside the chip. As the processors are software operated, in general, performance of CISC is lower than hardware operated RISC processor. However, the major point favoring the continued use of CISC processors is that of software compatibility. A massive base of software now runs on CISC (specially 80X86 series) processors. Till-today, the largest CISC processors manufacturer is the Intel Corporation of USA. Some companies, say Advanced Micro Device (AMD), Cyrix and Nexgen manufactures Intel clone processors. The only other CISC manufacturer is the Motorola corporation. A list of popular CISC processors is shown below :

## Microcomputers and Microprocessors

- Intel - 8085, 8088, 8086, 80286, 80386SX, 80386DX, 80486SX, 80486DX, Pentium, dual core, quad core etc.
- Motorola - 6800, 68000, 68010, 68020, 68030, 68040 etc.
- AMD - 386DX, 486DX, K5, Athol 64×2 dual core.
- Cyrix - 486DLC, 486SLC2, etc.
- IBM - 386SLC, 486SLC2, Blue lighting
- TI (Texas Instrument) - 486 SLC/E, 486 DLC/E etc.

### 3.4 RISC

RISC technology represents a recent development in the design of microprocessors. RISC CPUs have fewer and simpler instructions programmed into ROM, yet still have the capability of performing complex tasks. This feat is accomplished by combining simple instructions to form more complex ones. The advantage of the RISC architecture is speed, that is, processing time is greatly reduced. One currently finds RISC technology incorporated into the design of the CPUs used to drive workstations such as those developed by IBM and Sun Microsystems, Inc. Till now three basic problems of RISC processors are :

*The advantage of the RISC architecture is speed, that is, processing time is greatly reduced.*

- (i) PC software expects to see the Microsoft operating system environment and services.
- (ii) The applications have been compiled to operate on CISC based instruction set processors.
- (iii) Many older operating system based applications (and games) expect to see the exact PC hardware environment and then directly access the PC's hardware resources.

A list of popular RISC processors are given below :

- DEC (Digital Equipment Corporation) Alpha : 21064, 21064A, 21068 etc.
- SPARC ( Scaleable Processor Architecture) : TMS 390S10.
- IBM, Apple and Motorola Power PC : 601, 604, 603, 620 etc.
- MIPs (Million Instruction Per Second) - R10000.

### 3.5 Special Purpose Microprocessors

Special purpose microprocessors are used for specific applications or to enhance the performance of main processor. A coprocessor is an example of the special purpose processor.

*Special purpose microprocessors are used to enhance the performance of main processor.*

Most microcomputers support the use of one or more coprocessors. A coprocessor is a special microprocessor designed to perform one or more specific tasks. The most commonly used coprocessor is the math

## Computer Basics

coprocessor. Its use greatly speeds up the carrying out of numerical calculations. Current trend of microprocessor manufacturer is to incorporate the coprocessor within the main processor. Intel incorporated a math coprocessor into its 80486 and Pentium chips.

Other available coprocessors generally serve to enhance a computer's capabilities regarding the amount of systems and application software that will run on the computer. Examples: Intel 8087, 80287, 80387, 487 etc, Cyrix 83DS7, EMC87; Weitek 1167, 3167, 4167 etc.

### Digital Signal Processor

This is one of the most important category of processors for digital signal processing, well known as DSPs (digital signal processors). These processors are specifically designed to handle real-world analog signals that are converted to digital representations. These processors have very high performance instruction sets specifically designed to handle analog signal processing. Some of the applications that DSP can support are: (i) Sound and music synthesis, (ii) Modem functions, (iii) Speech synthesis, (iv) Speech recognition, (v) Graphics acceleration, (vi) Image processing.

*DSP are specifically designed to handle real-world analog signals that are converted to digital representations.*

Most popular DSP manufacturer is the Texas Instrument.

Examples: TMS 32010, TMS 320C40 etc.

### Other Processors

There are many other special purpose processors such as transputers (transistor + computer) used as parallel processing elements having special communication facility. Examples of transputers are: T425, T805, T9000 etc. Another category of future processors is VLIW (very long instruction word). The basic idea is to pack several simple unrelated instructions into a single super-instruction word and deliver it to the VLIW processor where it could be divided-up among a set of parallel execution units for simultaneous executions.



### 3.6 Exercise

#### 1. Multiple choice questions

- a. What class of processors are microcode operated?
  - (i) RISC
  - (ii) CISC
  - (iii) DSP
  - (iv) VLIW.
  
- b. Currently most successful microprocessor (for microcomputers) is:
  - (i) AMD
  - (ii) Cyrix
  - (iii) Motorola
  - (iv) Intel.
  
- c. Which processor has built-in coprocessor?
  - (i) 80486DX
  - (ii) 80386
  - (iii) 80286
  - (iv) none of them.

#### 2. Questions for short answers

- a. What is the basic difference between CISC and RISC?
- b. Give at least one example of CISC, RISC and DSP processors.
- c. What is the draw back of RISC based microcomputer?

#### 3. Analytical questions

- a. Write an essay on the different classes of microprocessors.
- b. What are the different classes of microprocessors? Briefly explain CISC and RISC processors with at least two examples of each.

